

B51 Servo Board Wiring Diagram

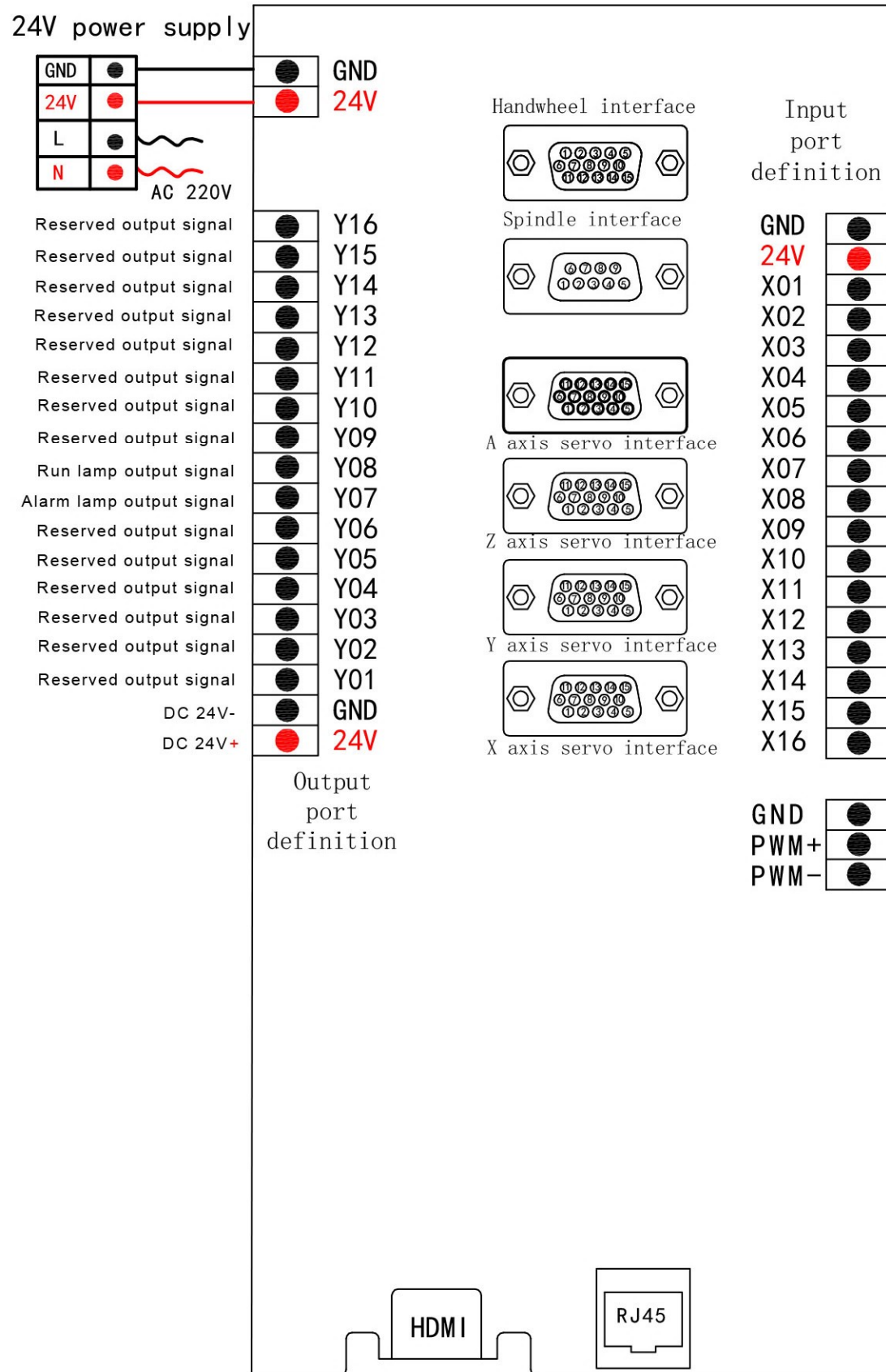

Handwheel interface

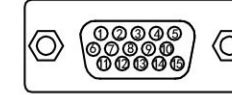

Handwheel interface pin definition

1	HX1	handwheel speed ratio X1
2	HX10	handwheel speed ratio X10
3	HX100	handwheel speed ratio X100
4	GND	return circuit ground
5	5V	5V
6	ESTOP	handwheel E-stop switch
7	HSX	handwheel axis selection X
8	HSY	handwheel axis selection Y
9	HSZ	handwheel axis selection Z
10	HS4	handwheel axis selection 4
11	HA+	handwheel encoder A+
12	HA-	handwheel encoder A-
13	HB+	handwheel encoder B+
14	HB-	handwheel encoder B-
15	HS5	handwheel axis selection 5

Spindle interface

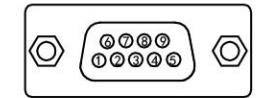

Spindle interface pin definition

1		N/A
2	INALM2	Inverter alarm input 2
3	SP CCW	SP CCW (SP2 CW)
4	SP CW	SP CW (SP1 CW)
5		N/A
6	OA1	Spindle analog output 1
7	OA2	Spindle analog output 2
8	INALM1	Inverter alarm input 1
9	GND	Return circuit ground

X axis servo interface

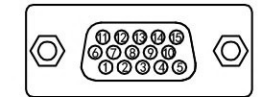

Servo axis interface pin definition

1	A+	servo encoder A+
2	A-	servo encoder A-
3	B+	servo encoder B+
4	B-	servo encoder B-
5	C+	servo encoder C+
6	24V	24V+
7	C-	servo encoder C-
8	ALM	servo alarm input
9	SRV ON	servo enable
10	SRV CLR	servo alarm clear
11	PULS+	pulse difference+
12	PULS-	pulse difference-
13	STGN+	pulse direction+
14	STGN-	pulse direction-
15	GND	24V return ground

Mechanical HOME switch

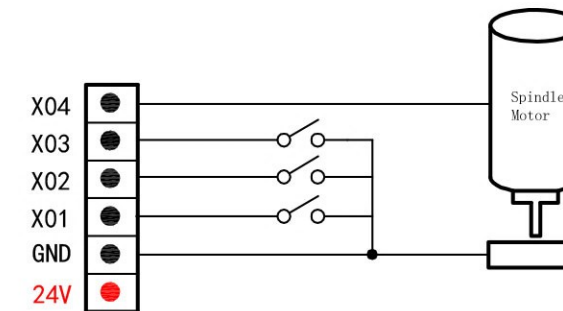

Photoelectric HOME switch

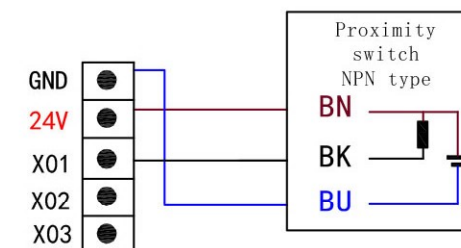

Model No.	B51 3 axis motion control system
Company Name	Beijing RichAuto S&T Corp., Ltd.