

BEIJING

RUIZHITIANHONG S&T Co.,Ltd

Engraving machine motion control system

A18-Four axis mechanical carving



Connection manual

JK0801-A Connection Board

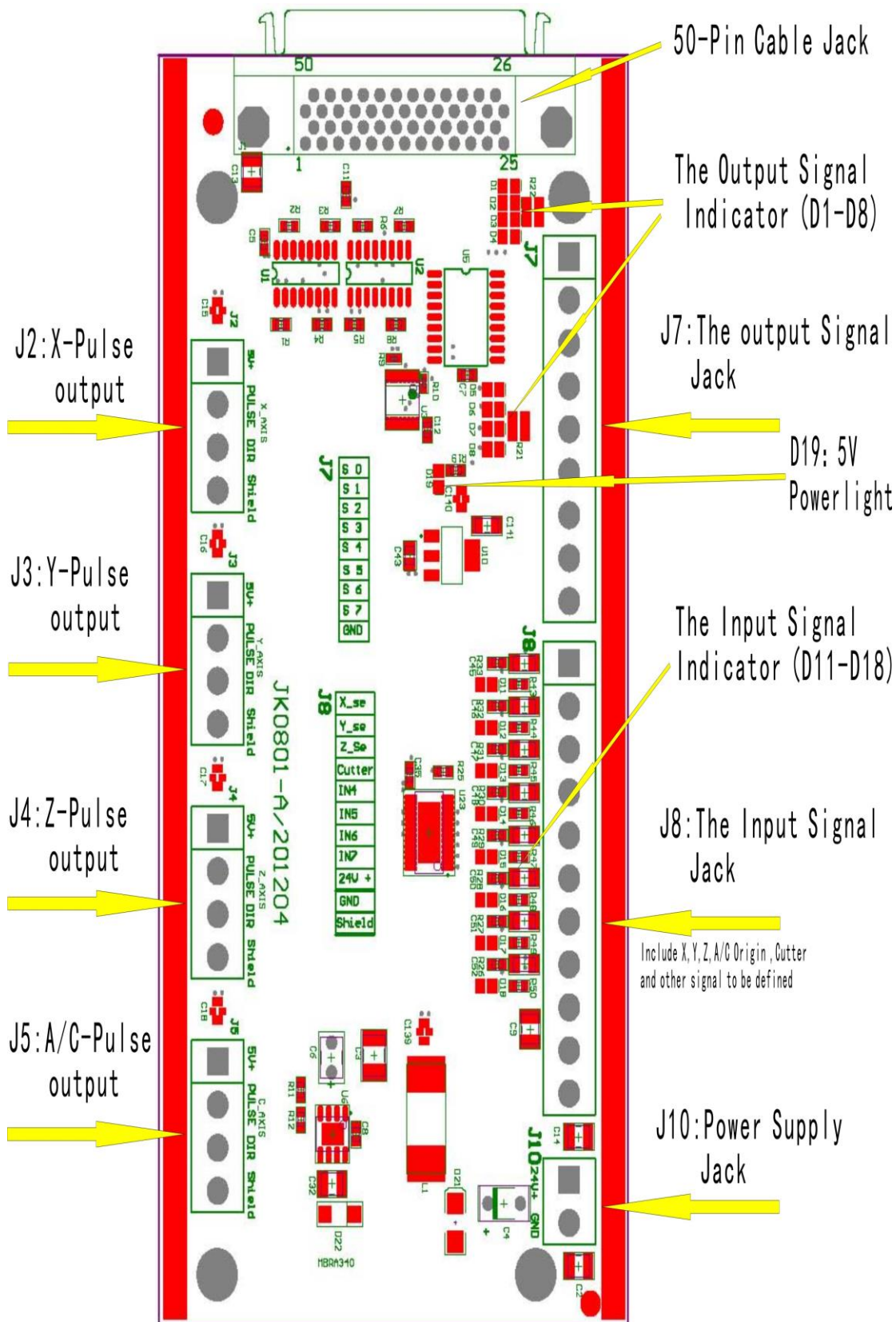
Board sketch map(50-pin upwards)



I/O State:

Port label	Port definition	Pin Definition	Pin functions and parameters	Notes
J10 	System Main power	System main power supply side	System main power supply terminal , interface board give DC 5V for system。 When F3 shorted can provide voltage to XYZ	Power area: DC10V~DC24V/3A ~40V
J 2 	X-axis pulse output port	Were positive signal output port	X-axis drive common anode power supply terminal 5V output	Do not impose voltage on this pin
		Pulse signal output port	X-axis drive pulse signal output port, the output voltage $\geq 3V$ drive current $\leq 8mA$	
		direction signal output port	X-axis direction of the drive signal output port output voltage $\geq 3V$ drive current $\leq 8mA$	
		Shield connection port	X-axis drive signal output voltage line terminal shield	Do not use this port for the grounding port
J 3 	Y-axis pulse output port	Were positive signal output port	Y-axis drive common anode power supply terminal 5V output	Do not impose voltage on this pin
		Pulse signal output port	Y-axis drive pulse signal output port, the output voltage $\geq 3V$ drive current $\leq 8mA$	
		direction signal output port	Y-axis direction of the drive signal output port output voltage $\geq 3V$ drive current $\leq 8mA$	
		Shield connection port	Y-axis drive signal output voltage line terminal shield	Do not use this port for the grounding port

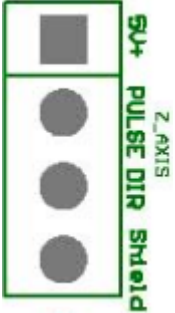
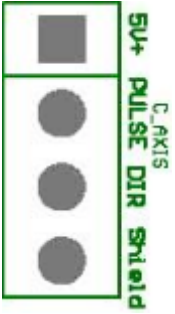
Port label	Port definition	Pin Definition	Pin functions and parameters	Notes
J 4 	Z-axis pulse output port	Were positive signal output port	Z-axis drive common anode power supply terminal 5V output	Do not impose voltage on this pin
		Pulse signal output port	Z-axis drive pulse signal output port, the output voltage $\geq 3V$ drive current $\leq 8mA$	
		direction signal output port	Z-axis direction of the drive signal output port output voltage $\geq 3V$ drive current $\leq 8mA$	
		Shield connection port	Z-axis drive signal output voltage line terminal shield	Do not use this port for the grounding port
J 5 	C-axis pulse output port	Were positive signal output port	C-axis drive common anode power supply terminal 5V output	Do not impose voltage on this pin
		Pulse signal output port	C-axis drive pulse signal output port, the output voltage $\geq 3V$ drive current $\leq 8mA$	
		direction signal output port	C-axis direction of the drive signal output port output voltage $\geq 3V$ drive current $\leq 8mA$	
		Shield connection port	C-axis drive signal output voltage line terminal shield	Do not use this port for the grounding port

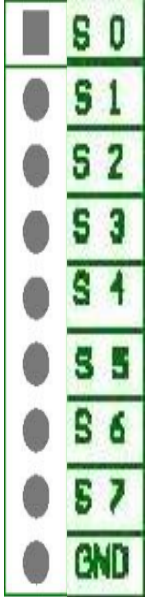

Port label	Port definition	Pin Definition	Pin functions and parameters	Notes
J 7 	Output Control terminal	Y1(S0): Spindle ON/OFF	Connect to FWD of inverter	Output Low level signal
		Y2(S1): speed 1	Connect to inverter to control speed	Output Low level signal
		Y3(S2): speed 2	Connect to inverter to control speed	Output Low level signal
		Y4(S3): speed 3	Connect to inverter to control speed	Output Low level signal
		Y5(S4): Alarm LED	Light when there is something wrong with system	Output Low level signal
		Y6(S5): Work LED	Light when system works	Output Low level signal
		Y7(S6): definable	user-defined signal	Output Low level signal
		Y8(S7): definable	user-defined signal	Output Low level signal
		GND:output GND		GND connect to this terminal in control inverter speed mode

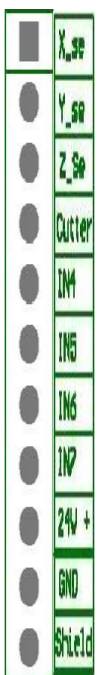
PS: All the pin terminals are for the parties sort the mouth as the first one, the bit serial extended direction of the arrow.

Port label	Port definition	Pin Definition	Pin functions and parameters	Notes
J 8 	input Control terminal	X1: X_se: X origin sensor signal input	X origin sensor signal input terminal	Input low level signals
		X2: Y_se: Y origin sensor signal input	Y origin sensor signal input terminal	Input low level signals
		X3: Z_se: Z origin sensor signal input	Z origin sensor signal input terminal	Input low level signals
		X4: A/Z origin sensor signal input	A/Z origin sensor signal input terminal	Input low level signals
		X5: Tool-setting sensor signal input	Tool-setting sensor signal input terminal	Input low level signals
		X6: definable signal input	definable signal input terminal I	Input low level signals
		X7: definable signal input	definable signal input terminal	Input low level signals
		X8 : definable signal input	definable signal input terminal	Input low level signals
		24V+ : Sensor power input	X、 Y、 Z sensor isolate circuit power supply positive input terminal	Sensor isolate circuit supply voltage range DC10V~DC24V
		GND: GDN input	X、 Y、 Z sensor isolate circuit power supply negative input terminal	
		Shield: Shield input	Sensor signal cable shield input terminal	Do not use this port as a negative use of the sensor isolation circuit power

PS: All the pin terminals are for the parties sort the mouth as the first one, the bit serial extended direction of the arrow.

Port label	Port definition	Pin Definition	Pin functions and parameters	Notes
	D19	Power LED	Interface board 5V indicator indicate the interface and internal power supply status moderators	Lights after power

Port label	Port definition	Pin Definition	Pin functions and parameters	Notes
	D11	Status indicator	X origin status indicator	Light after power. Input low level signal, the lights will be put out. Release the signal, the lights will be bright again
	D12	Status indicator	Y origin status indicator	
	D13	Status indicator	Z origin status indicator	
	D14	Status indicator	A/Z origin status indicator	
	D15	Status indicator	Tool-setting Status indicator	
	D16	Status indicator	definable signal status indicator	
	D17	Status indicator	definable signal status indicator	
	D18	Status indicator	definable signal status indicator	
	D1	Status indicator	output terminal Y1 status indicator	Output low level signal when the system works
	D2	Status indicator	output terminal Y2 status indicator	
	D3	Status indicator	output terminal Y3 status indicator	
	D4	Status indicator	output terminal Y4 status indicator	
	D5	Status indicator	output terminal Y5 status indicator	
	D6	Status indicator	output terminal Y6 status indicator	
	D7	Status indicator	output terminal Y7 status indicator	
	D8	Status indicator	output terminal Y8 status indicator	

PS: All the pin terminals are for the parties sort the mouth as the first one, the bit serial extended direction of the arrow.

Cable Plug

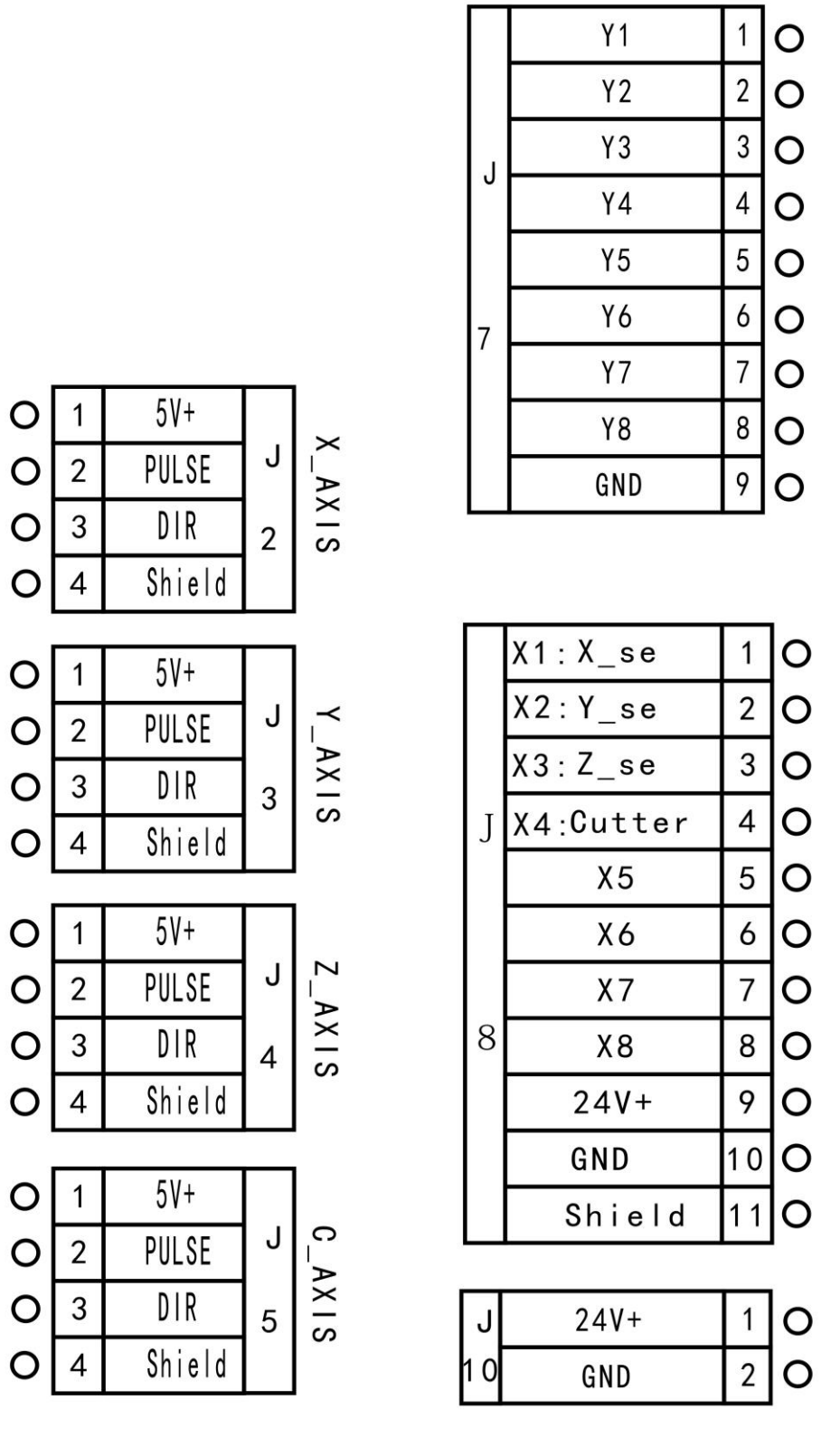

Stepper Motor Driver&NPN(NO):

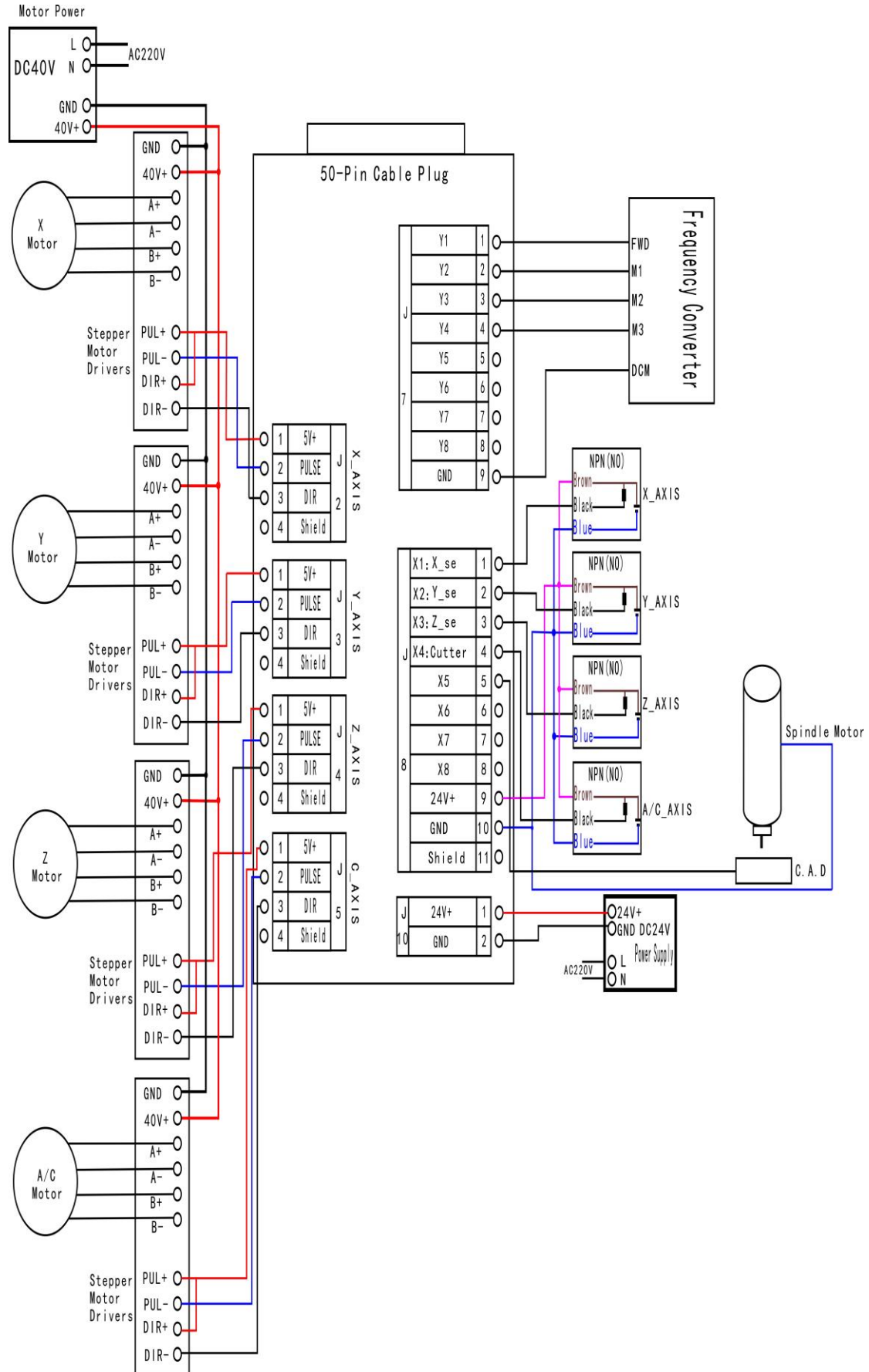

Different Stepper Motor Drivers:

1

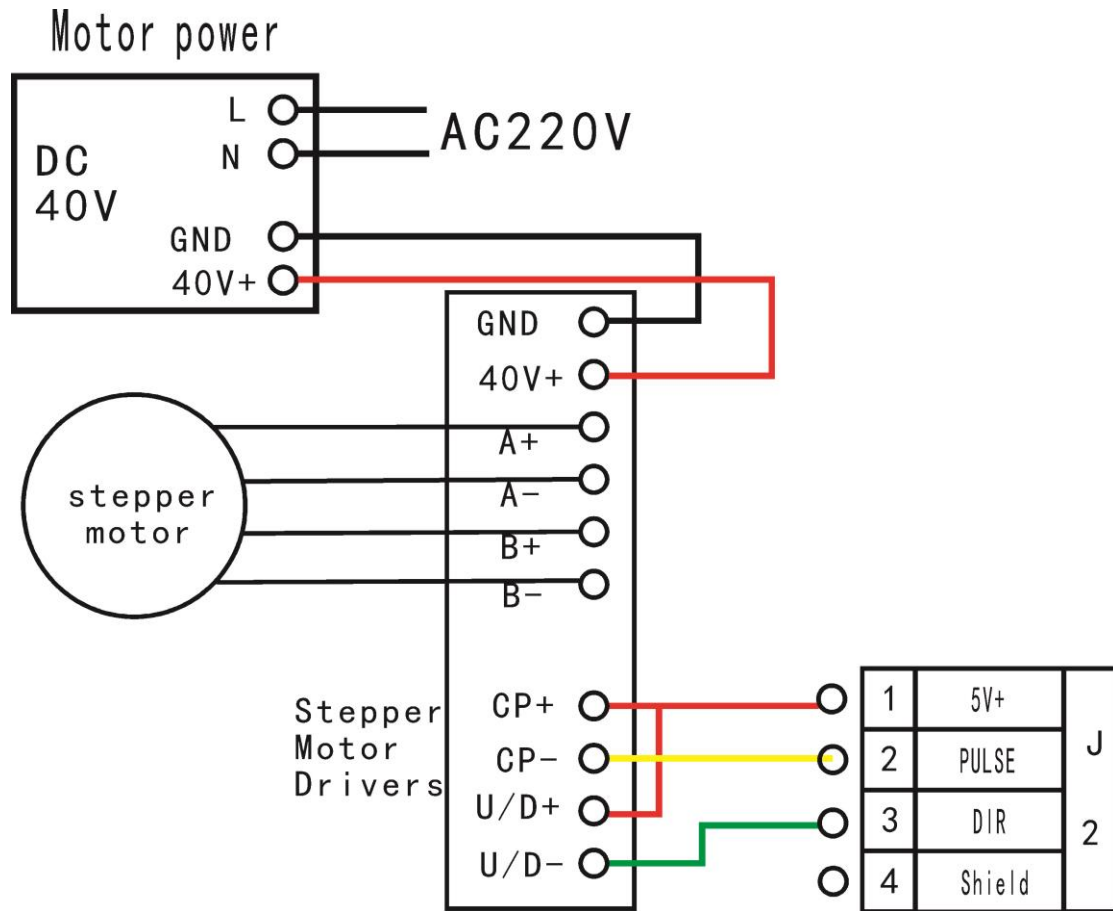

2

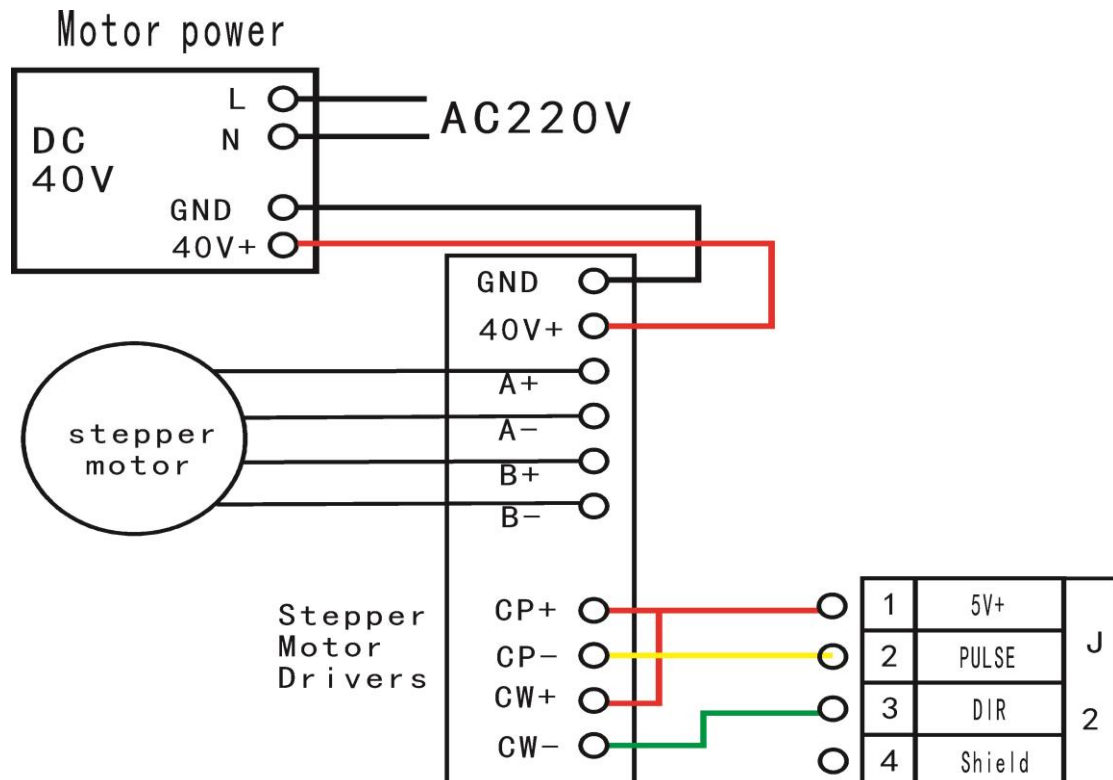

3

Motor power

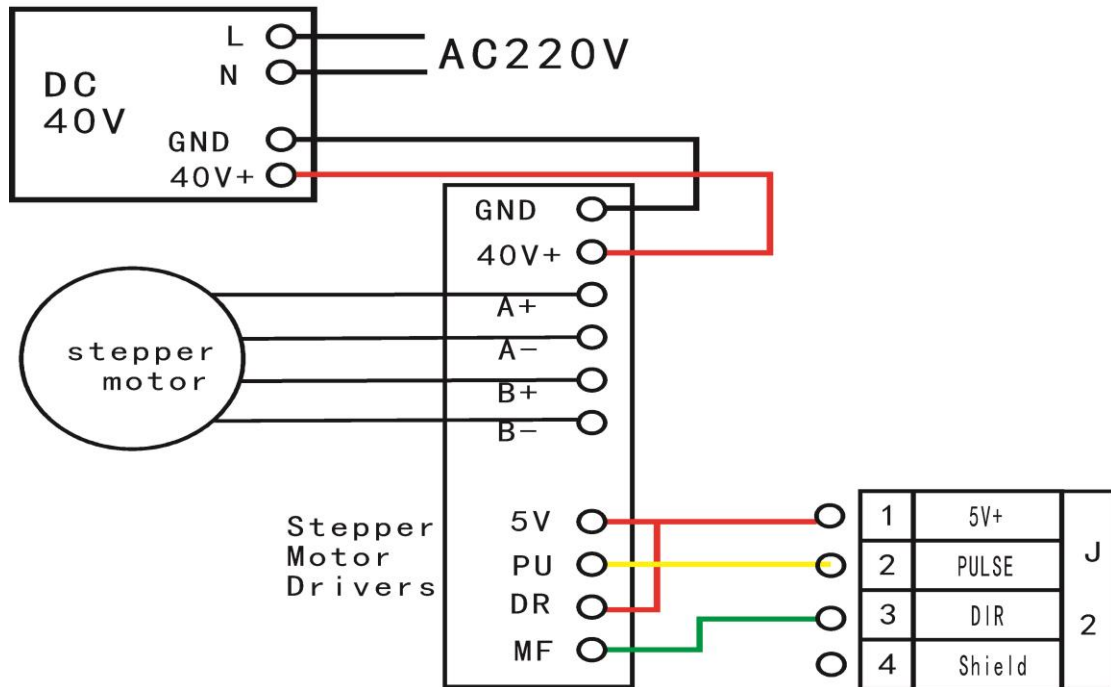

4

Motor power

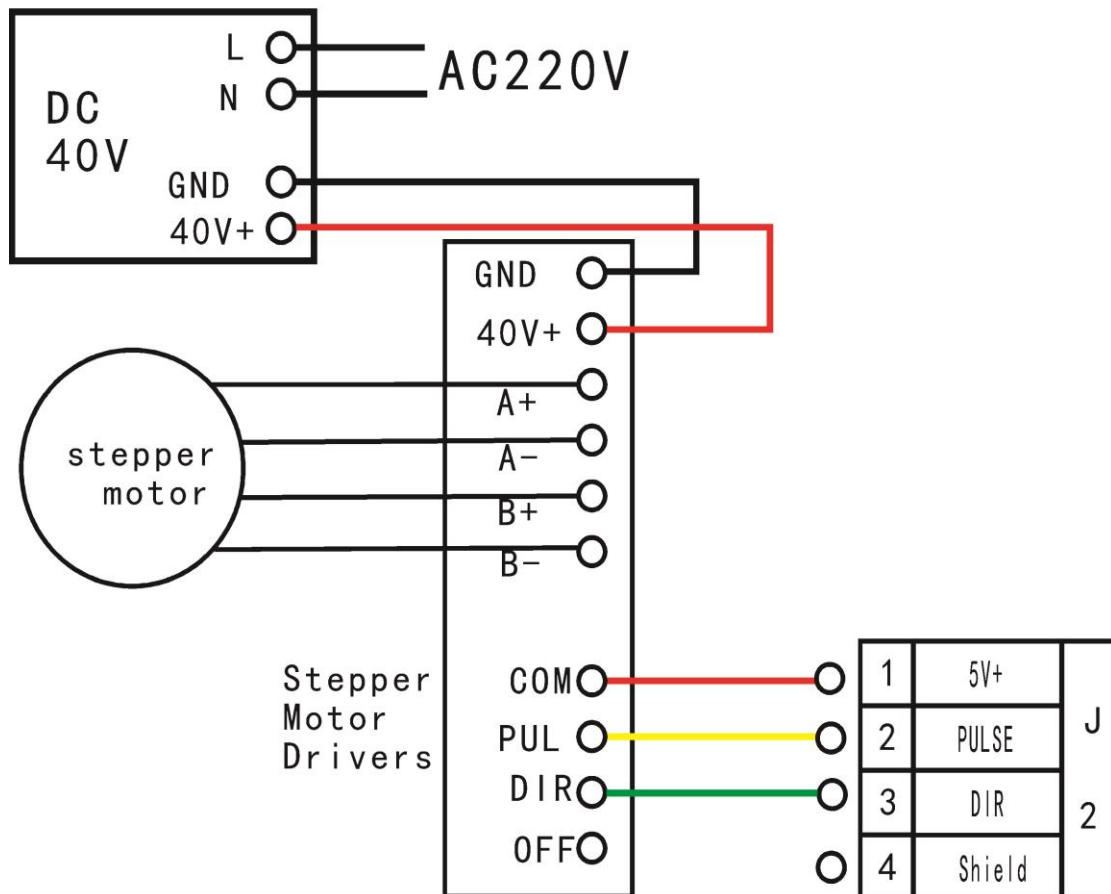

YASKAWA SERVO MOTOR:

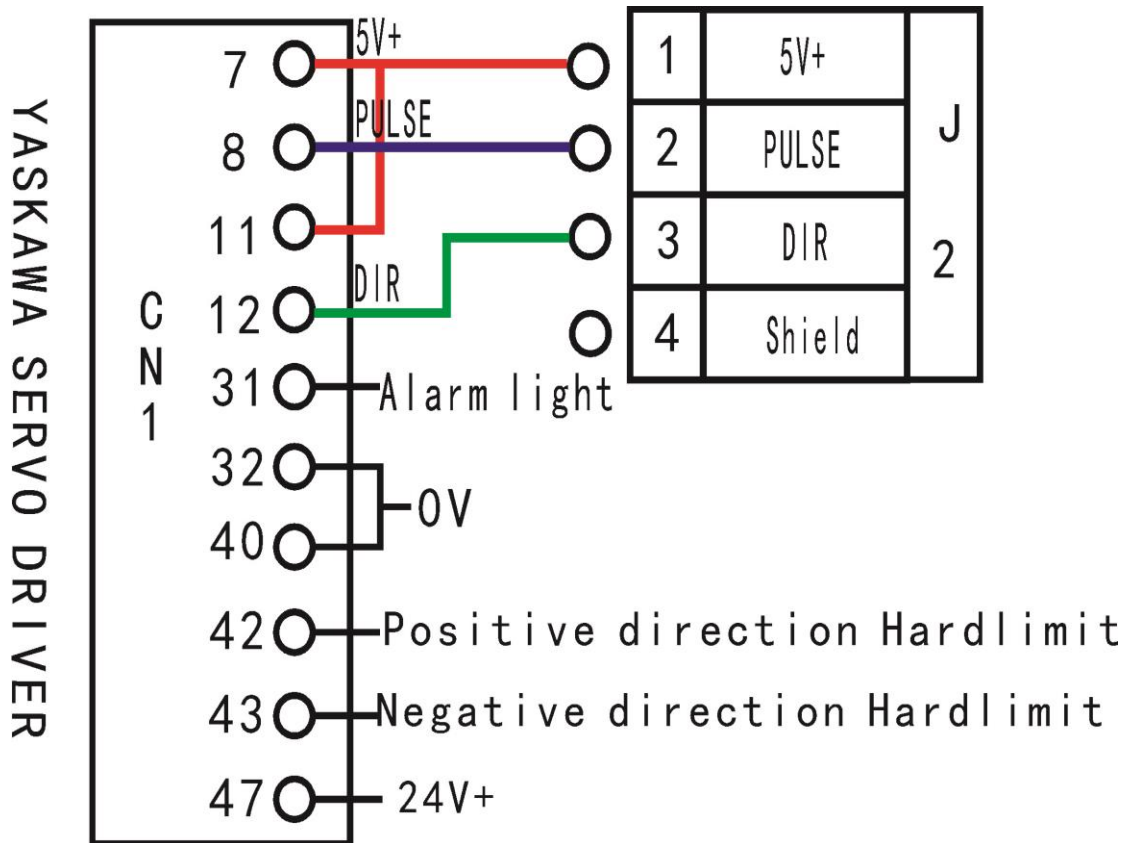

Input Control Terminal J8

1 sensor input ①Mechanical: Ordinary axis (Y,Z are the same as X)

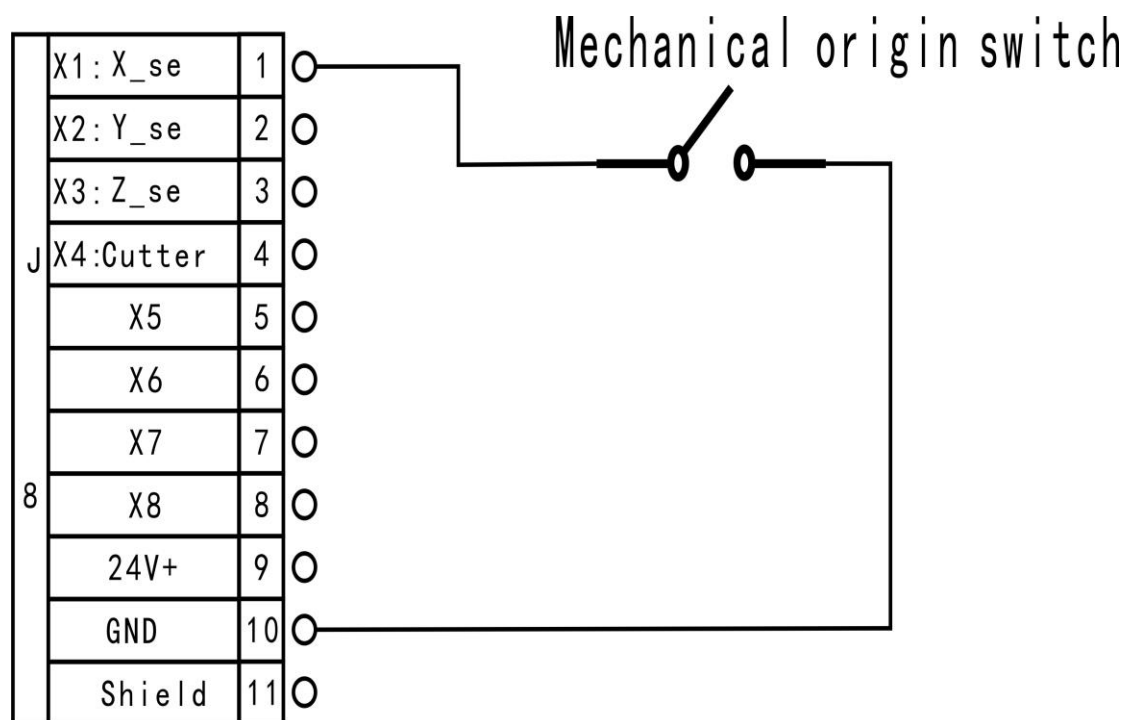

Rotation axis:

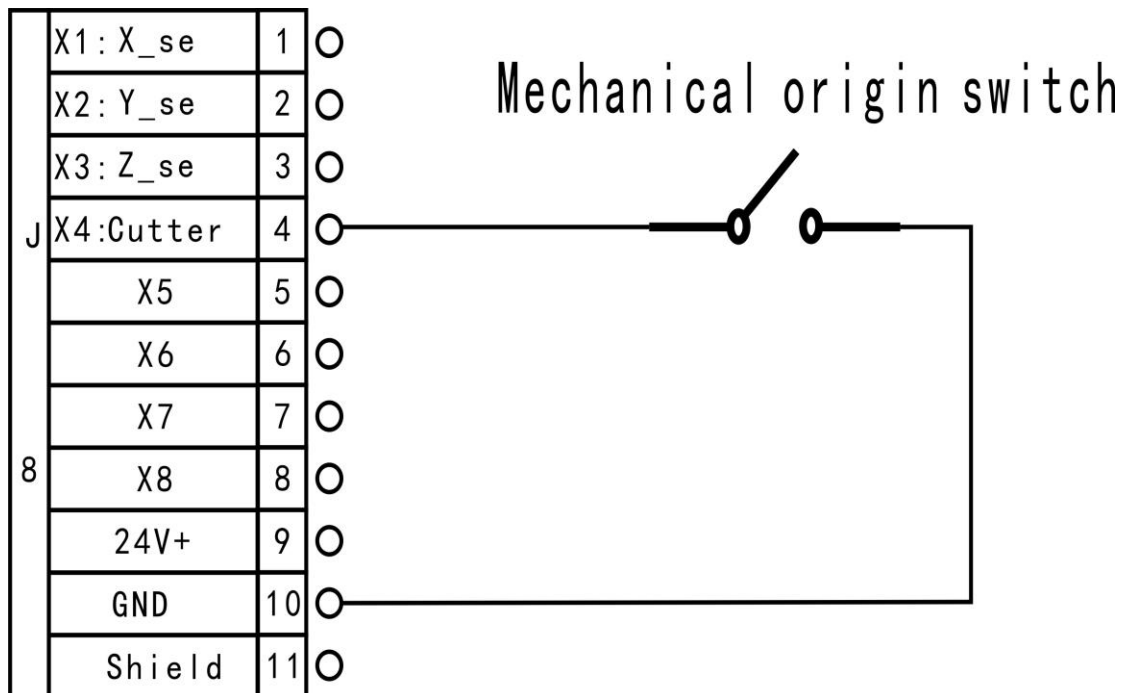

② NPN(NO): Ordinary axis (Y,Z are the same as X)

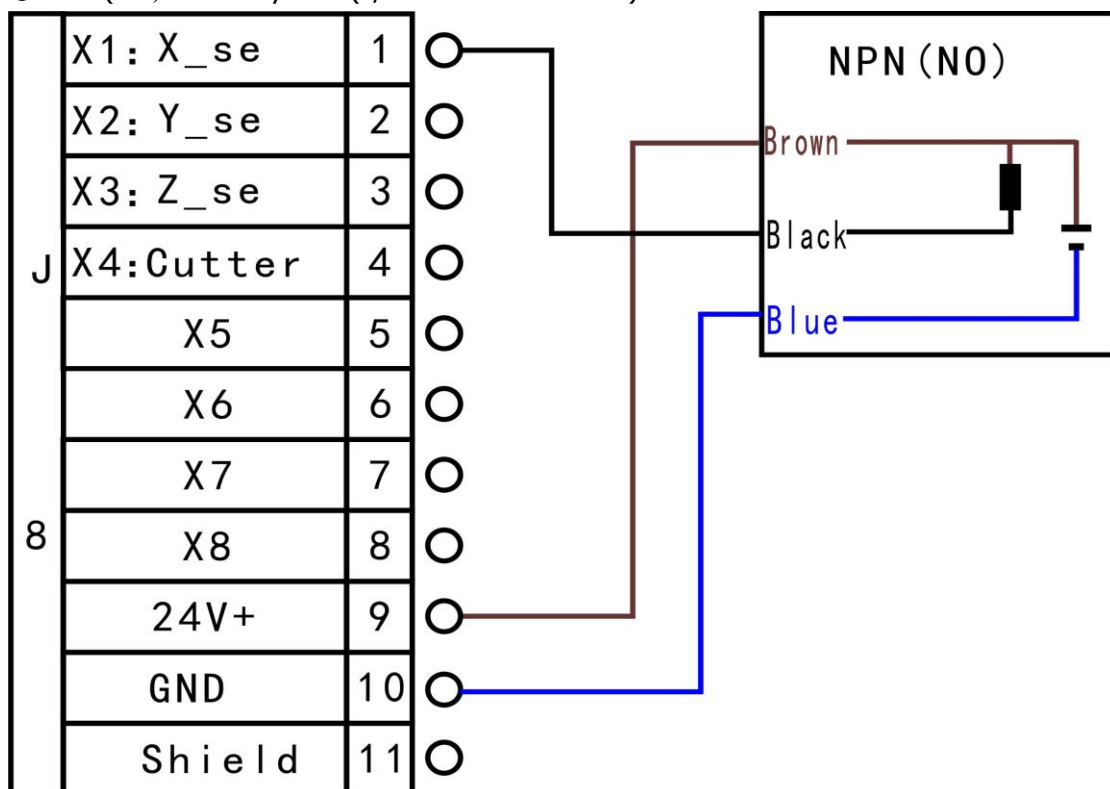

Rotation axis:

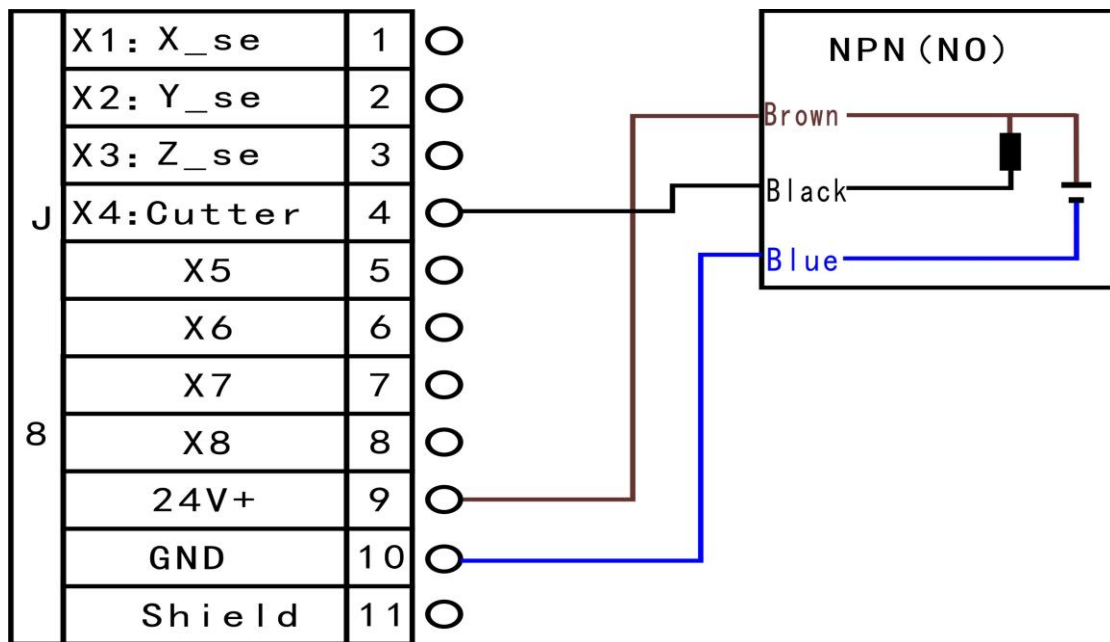

③ PNP(NO) : Ordinary axis (X and Z are the same as Y)

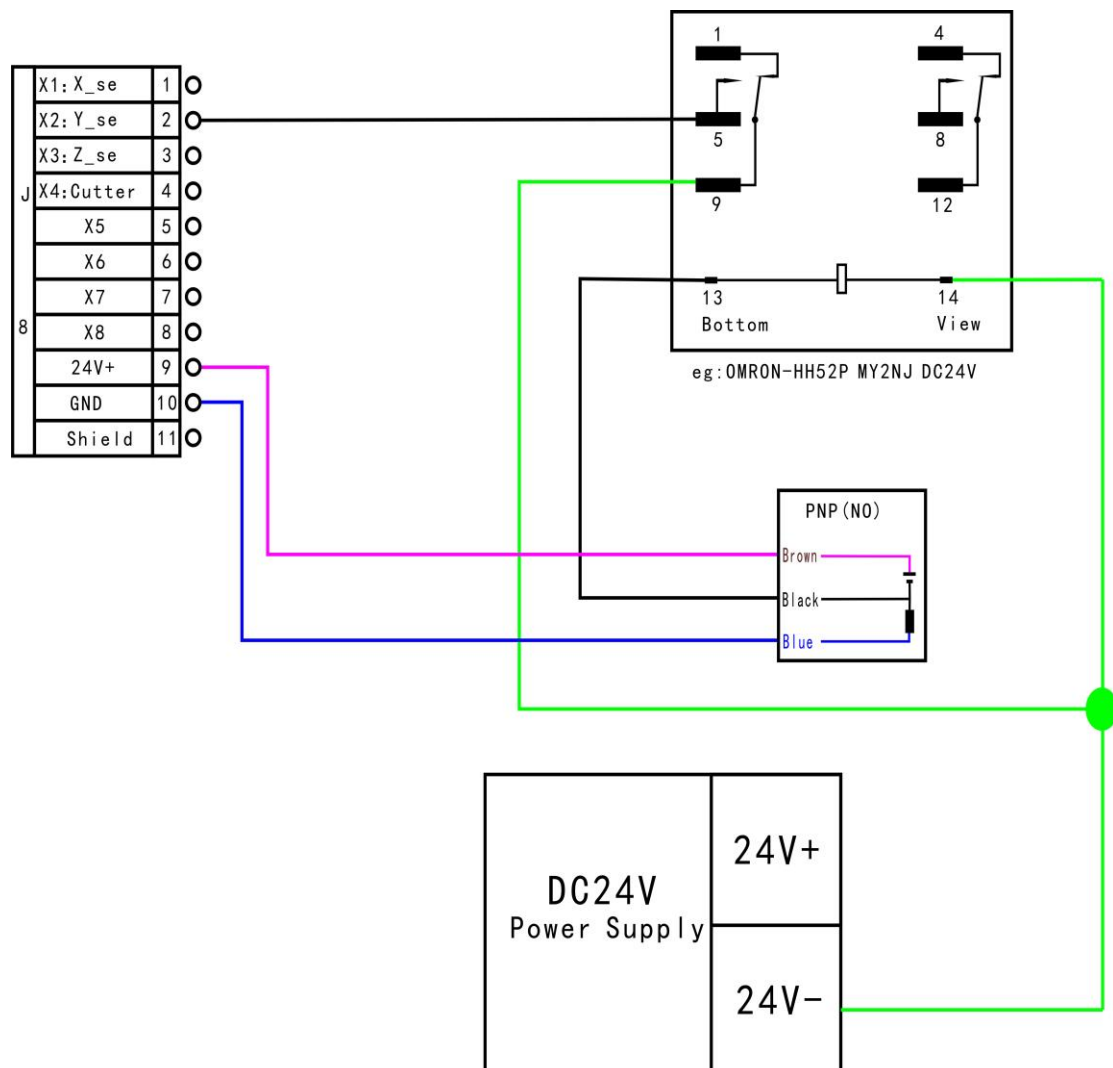

Rotation axis:

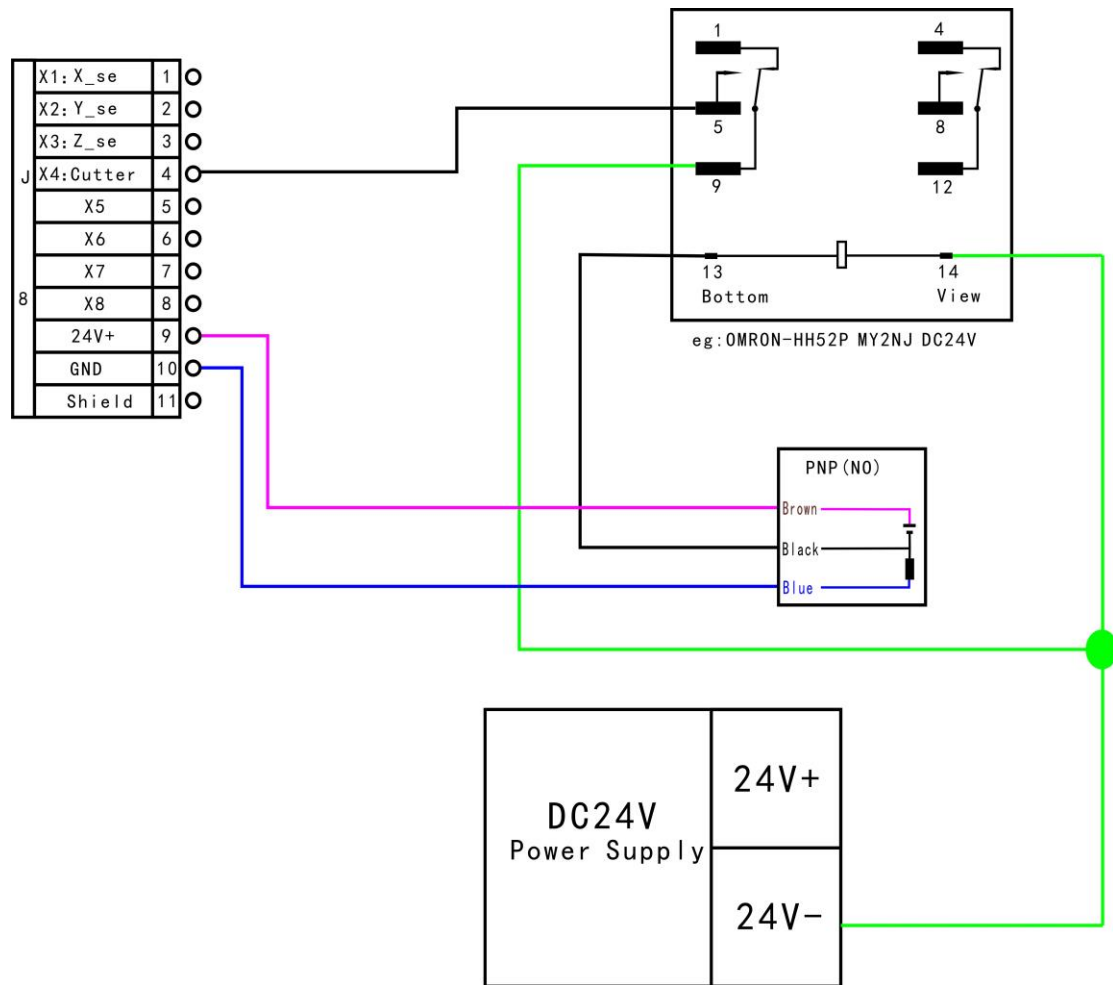

2 Tool-setting input: Tool-setting detecting wiring:

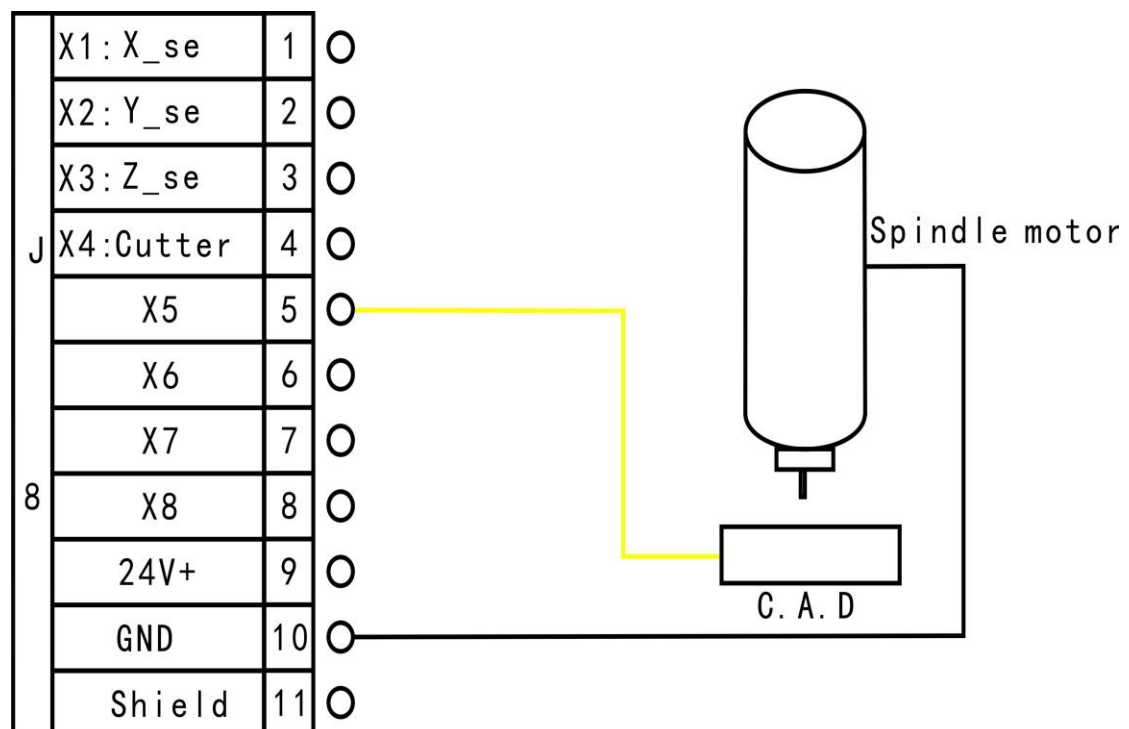

J 10 Main power wiring:

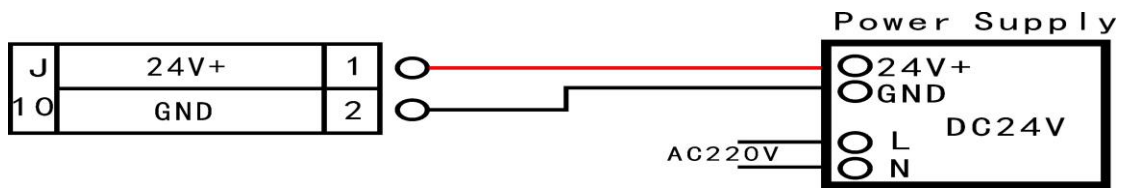

Output Control Terminal J7

J2 X pulse signal wiring (Y, Z the same as X)

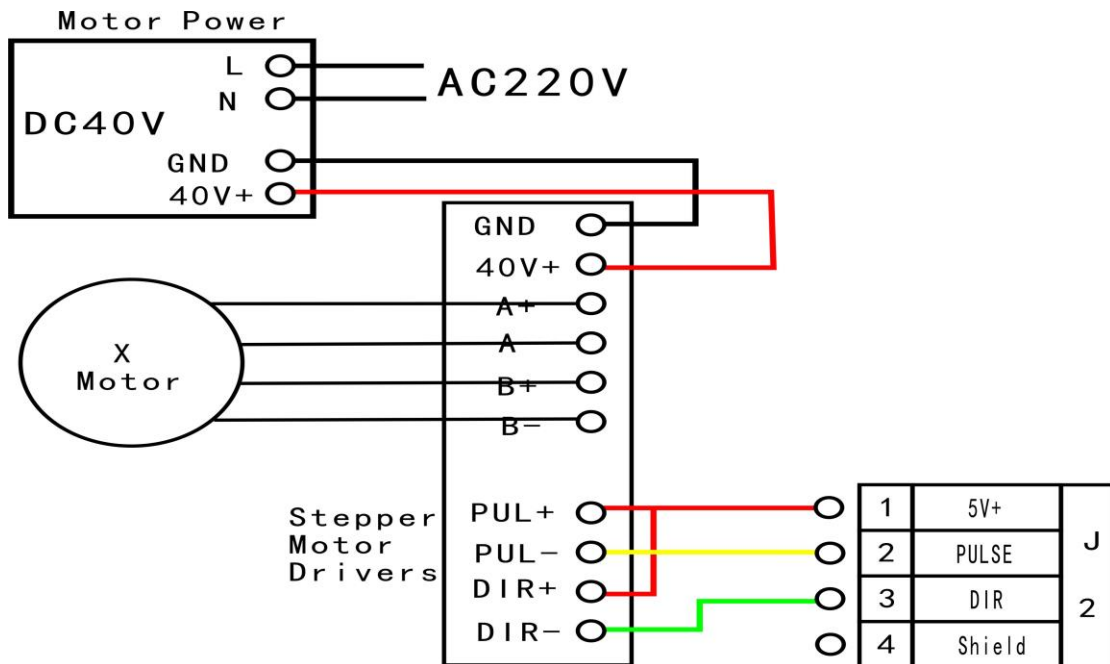

J7 output control terminal

Spindle output wiring examples:

1 spindle on/off

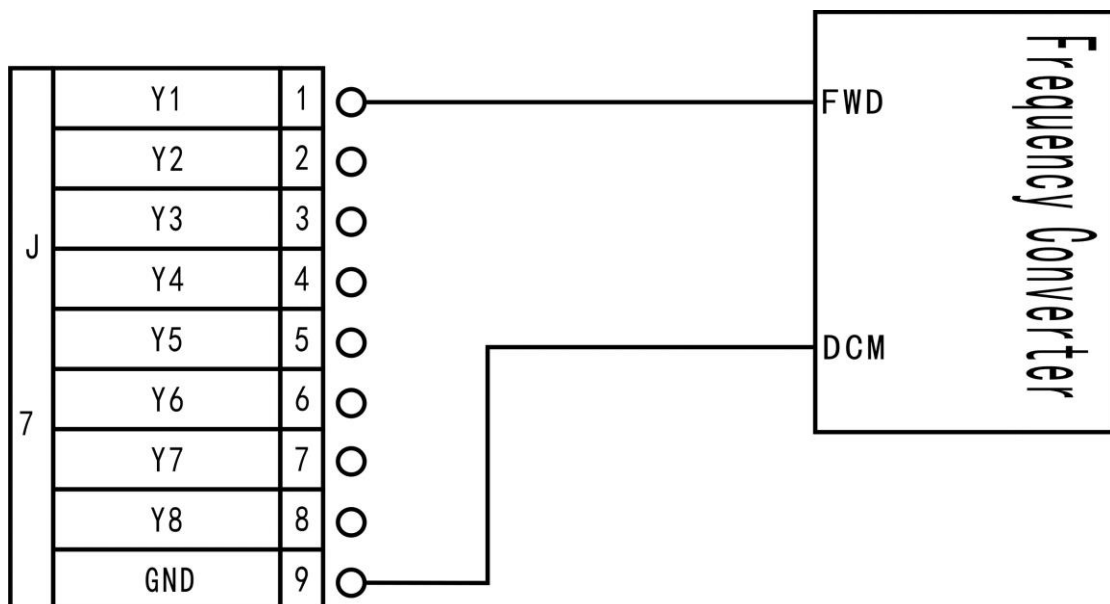

2 Multi-speed

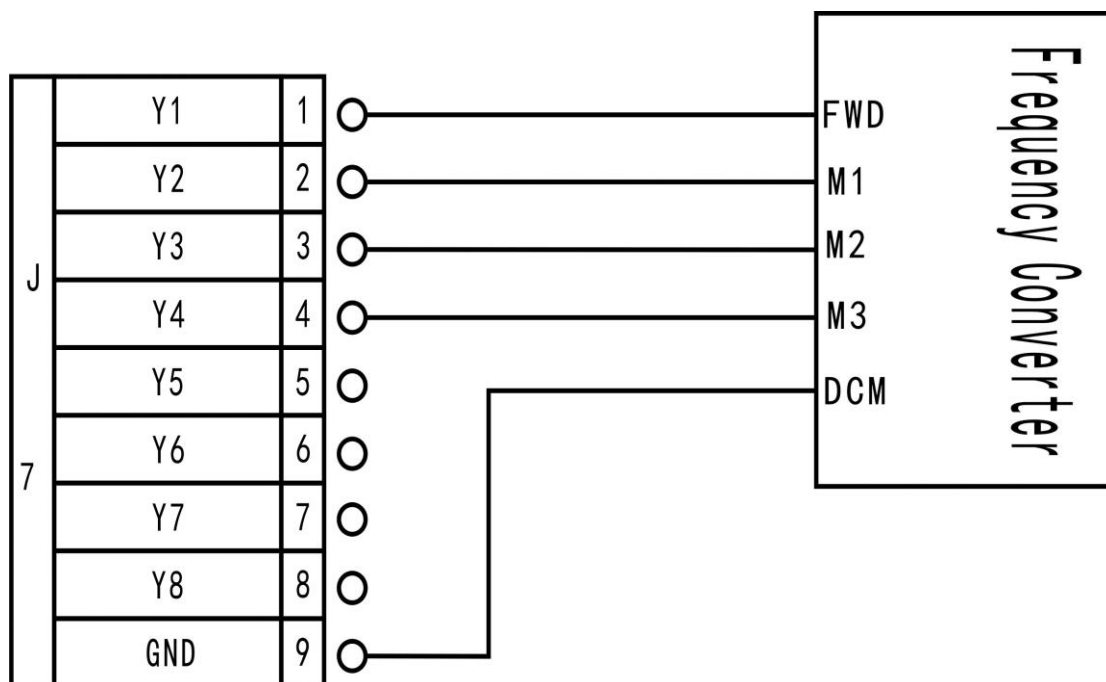

PS: FWD and DCM has Connected in Parallel in some inverters, please do not need to connect Y1 (S0) in such situations, you only need to connect DCM with GND of interface board, without having to re-set the spindle gear.

Output Y5-Alarm LED and Y6-WORK LED:

